

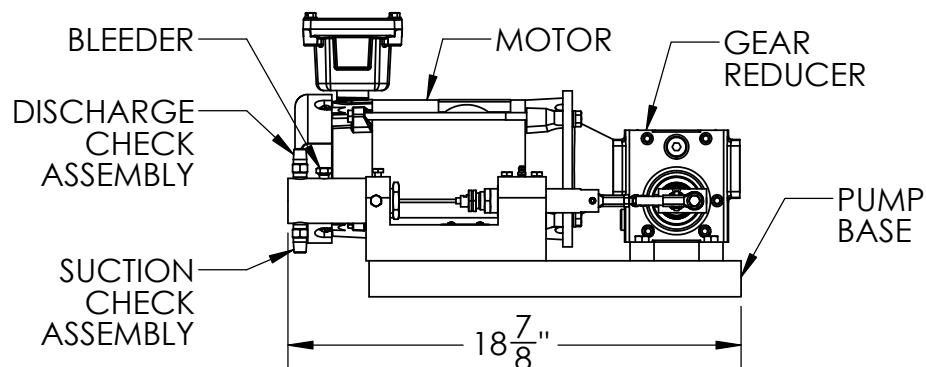

# McFarland – TriTan, LLC

The "High Pressure" Specialists!  
 www.mcfarlandpumpgroup.com  
 Phone: (713) 864-3366 FAX: (713) 864-3252

# STONEBOR MODEL A SIMPLEX CHEMICAL INJECTION PUMP

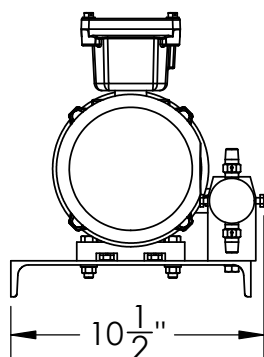
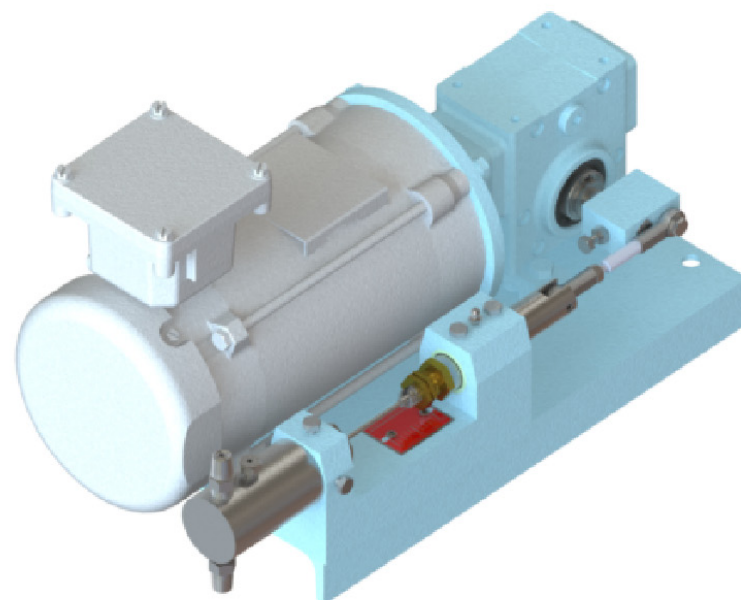
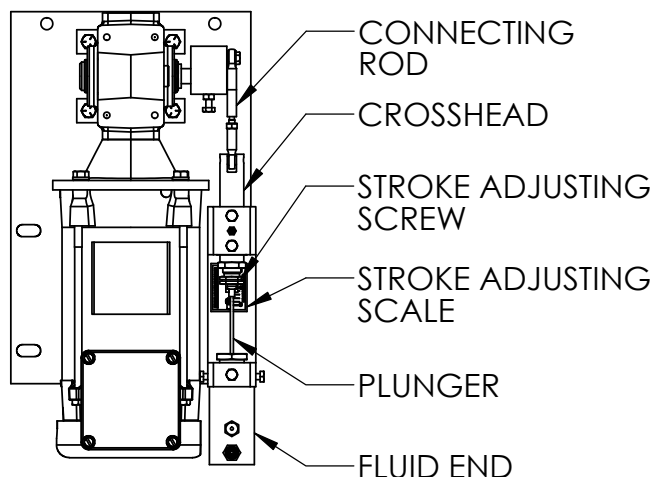

| MODEL     | Volume Gal./Day | Plunger Size (in.) | Max Discharge Pressure (PSI) | Stroke (Max) | Speed Strokes/Minute |
|-----------|-----------------|--------------------|------------------------------|--------------|----------------------|
| A-S-125-A | 3.62            | 1/8                | 5,000                        | 1.5"         | 35                   |
| A-S-125-B | 9.04            | 1/8                | 5,000                        | 1.5"         | 87.5                 |
| A-S-250-A | 14.46           | 1/4                | 2,500                        | 1.5"         | 35                   |
| A-S-250-B | 36.15           | 1/4                | 2,500                        | 1.5"         | 87.5                 |
| A-S-375-A | 32.53           | 3/8                | 1,500                        | 1.5"         | 35                   |
| A-S-375-B | 81.33           | 3/8                | 1,500                        | 1.5"         | 87.5                 |
| A-S-500-A | 57.83           | 1/2                | 500                          | 1.5"         | 35                   |
| A-S-500-B | 144.58          | 1/2                | 500                          | 1.5"         | 87.5                 |

Model A & Model B electric pumps are designed for continuous and intermittent pumping of chemical and corrosive fluids.

**Features:**

- Positive displacement, self-priming plunger
- Mounted on fabricated steel base
- Powered by electric motor through a gear reducer
- Fluid contacting components - 300 series stainless steel

**Applications:**

- Plant Operations
- Research
- Oilfield Applications
- Refineries
- Water Treatment for boilers
- Injection of precise small volumes

\* MOTORS ARE 1/4 HP  
 APPROX. WEIGHT: 110 LBS.



# McFarland – TriTan, LLC

The "High Pressure" Specialists!  
 www.mcfarlandpumpgroup.com  
 Phone: (713) 864-3366 FAX: (713) 864-3252

# STONEBOR MODEL A DUPLEX CHEMICAL INJECTION PUMP

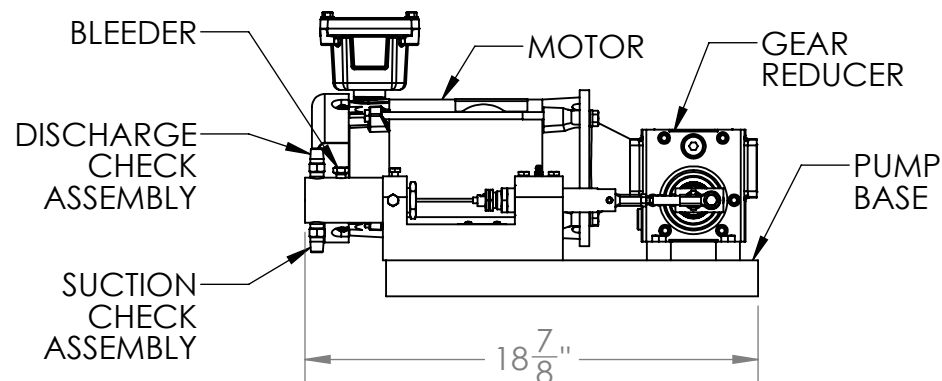
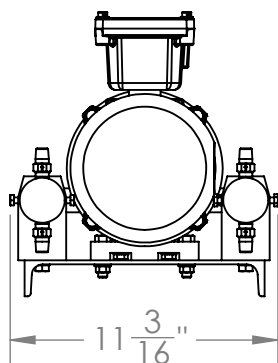
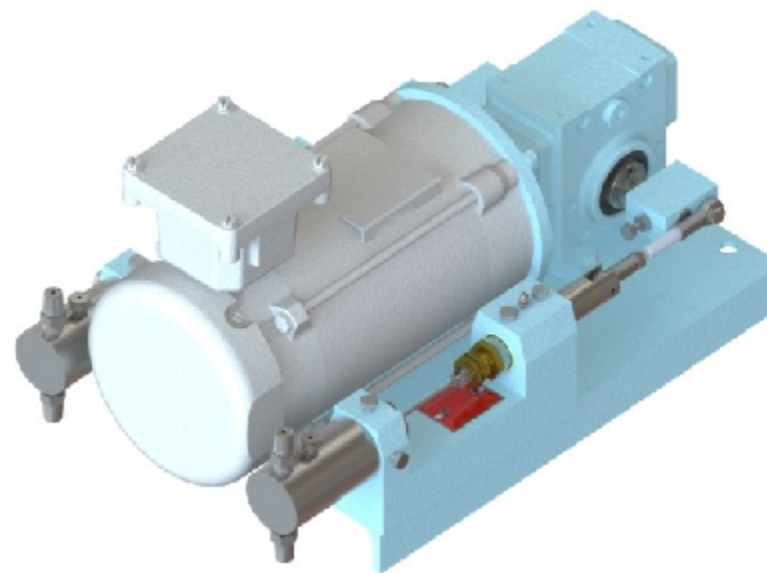
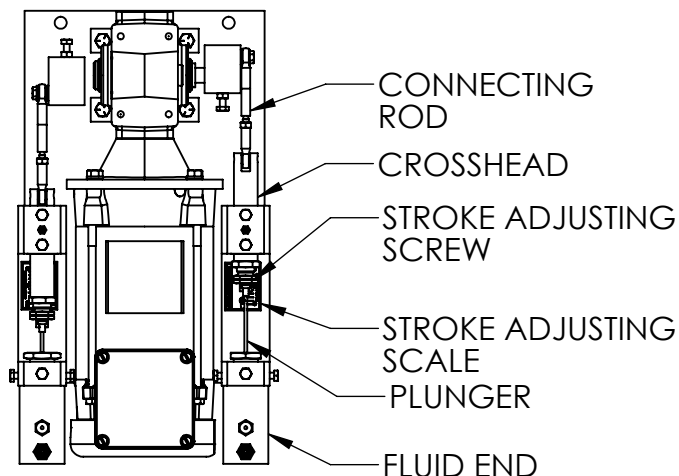

| MODEL     | Volume Gal./Day | Plunger Size (in.) | Max Discharge Pressure (PSI) | Stroke (Max) | Speed Strokes/Minute |
|-----------|-----------------|--------------------|------------------------------|--------------|----------------------|
| A-D-125-A | 7.23            | 1/8                | 5,000                        | 1.5"         | 35                   |
| A-D-125-B | 18.07           | 1/8                | 5,000                        | 1.5"         | 87.5                 |
| A-D-250-A | 28.92           | 1/4                | 2,500                        | 1.5"         | 35                   |
| A-D-250-B | 72.30           | 1/4                | 2,500                        | 1.5"         | 87.5                 |
| A-D-375-A | 65.06           | 3/8                | 1,500                        | 1.5"         | 35                   |
| A-D-375-B | 162.66          | 3/8                | 1,500                        | 1.5"         | 87.5                 |
| A-D-500-A | 115.66          | 1/2                | 500                          | 1.5"         | 35                   |
| A-D-500-B | 289.16          | 1/2                | 500                          | 1.5"         | 87.5                 |

\* MOTORS ARE 1/4 HP  
 APPROX. WEIGHT: 130 LBS.

Model A & Model B electric pumps are designed for continuous and intermittent pumping of chemical and corrosive fluids.

### Features:

- Positive displacement, self-priming plunger
- Mounted on fabricated steel base
- Powered by electric motor through a gear reducer
- Fluid contacting components - 300 series stainless steel

### Applications:

- Plant Operations
- Research
- Oilfield Applications
- Refineries
- Water Treatment for boilers
- Injection of precise small volumes



# McFarland – TriTan, LLC

The "High Pressure" Specialists!  
 www.mcfarlandpumpgroup.com  
 Phone: (713) 864-3366 FAX: (713) 864-3252

# STONEBOR MODEL A QUADRUPLEX CHEMICAL INJECTION PUMP

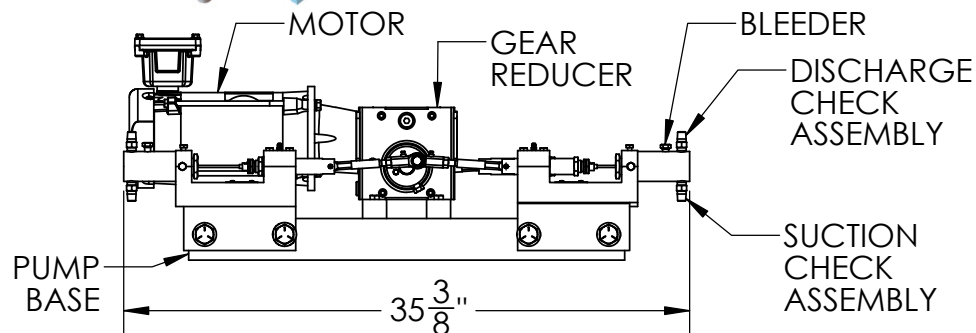
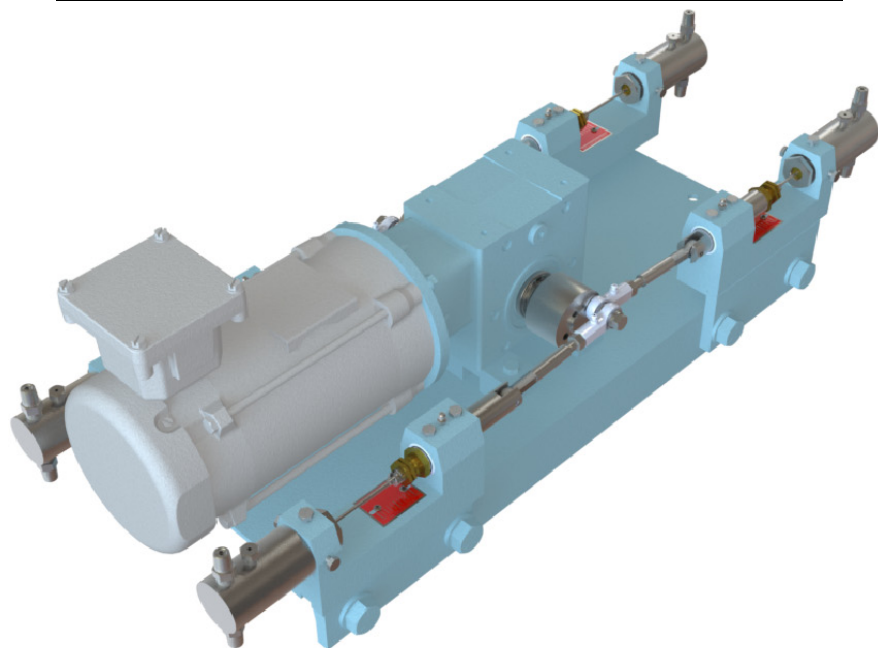
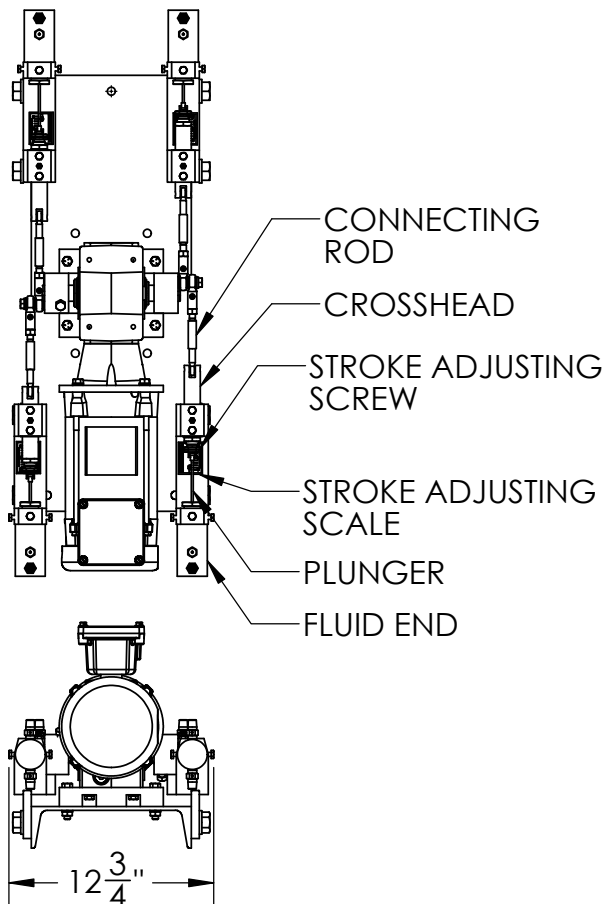

| MODEL     | Volume Gal./Day | Plunger Size (in.) | Max Discharge Pressure (PSI) | Stroke (Max) | Speed Strokes/Minute |
|-----------|-----------------|--------------------|------------------------------|--------------|----------------------|
| A-Q-125-A | 14.46           | 1/8                | 5,000                        | 1.5"         | 35                   |
| A-Q-125-B | 28.51           | 1/8                | 5,000                        | 1.5"         | 69                   |
| A-Q-250-A | 57.84           | 1/4                | 3,000                        | 1.5"         | 35                   |
| A-Q-250-B | 114.03          | 1/4                | 2,500                        | 1.5"         | 69                   |
| A-Q-375-A | 130.12          | 3/8                | 1,500                        | 1.5"         | 35                   |
| A-Q-375-B | 256.52          | 3/8                | 1,500                        | 1.5"         | 69                   |
| A-Q-500-A | 231.32          | 1/2                | 500                          | 1.5"         | 35                   |
| A-Q-500-B | 456.03          | 1/2                | 500                          | 1.5"         | 69                   |

Model A & Model B electric pumps are designed for continuous and intermittent pumping of chemical and corrosive fluids.

**Features:**

- Positive displacement, self-priming plunger
- Mounted on fabricated steel base
- Powered by electric motor through a gear reducer
- Fluid contacting components - 300 series stainless steel

**Applications:**

- Plant Operations
- Research
- Oilfield Applications
- Refineries
- Water Treatment for boilers
- Injection of precise small volumes

\* MOTORS ARE 1/4 HP  
 APPROX. WEIGHT: 200 LBS.



# McFarland – TriTan, LLC

The "High Pressure" Specialists!  
 www.mcfarlandpumpgroup.com  
 Phone: (713) 864-3366 FAX: (713) 864-3252

# STONEBOR MODEL B DUPLEX CHEMICAL INJECTION PUMP

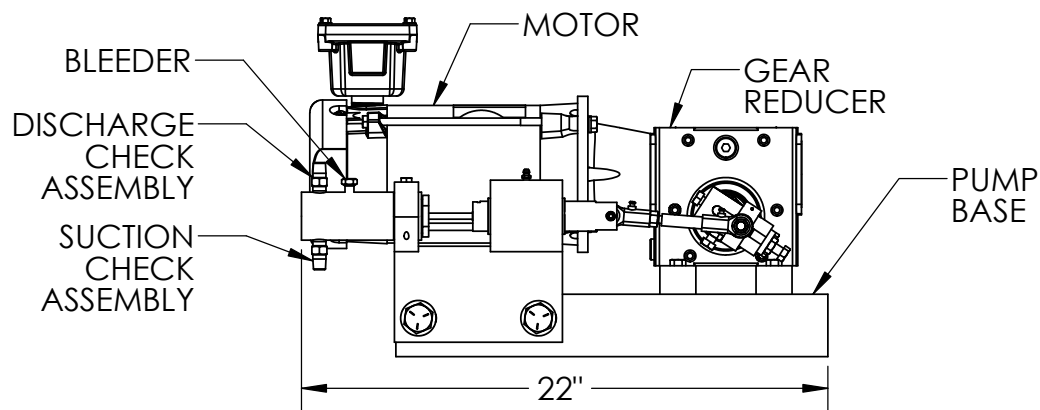
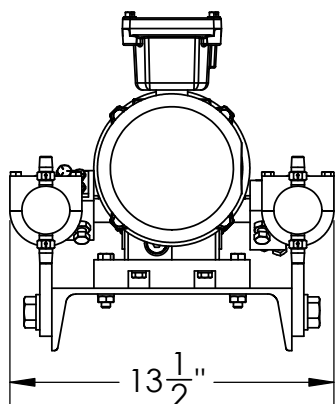
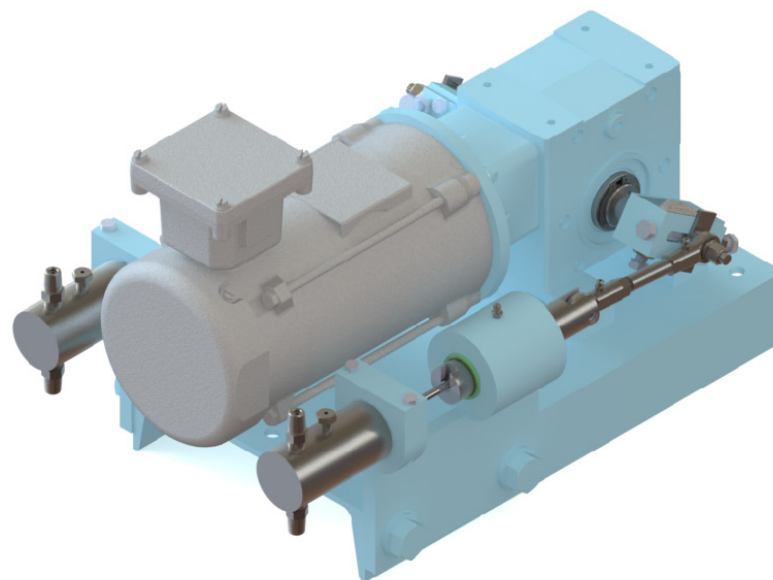
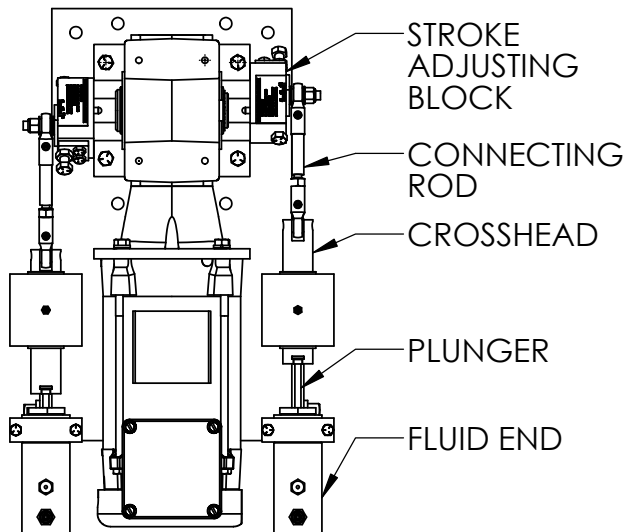

| MODEL      | Volume Gal./Day | Plunger Size (in.) | Max Discharge Pressure (PSI) | Stroke (Max) | Speed Strokes/Minute |
|------------|-----------------|--------------------|------------------------------|--------------|----------------------|
| B-D-250-A  | 72.30           | 1/4                | 4,000                        | 1.5"         | 87.5                 |
| B-D-375-A  | 162.66          | 3/8                | 3,000                        | 1.5"         | 87.5                 |
| B-D-500-A  | 289.16          | 1/2                | 1,750                        | 1.5"         | 87.5                 |
| B-D-750-A  | 650.64          | 3/4                | 800                          | 1.5"         | 87.5                 |
| B-D-1000-A | 1,156.70        | 1                  | 500                          | 1.5"         | 87.5                 |

Model A & Model B electric pumps are designed for continuous and intermittent pumping of chemical and corrosive fluids.

**Features:**

- Positive displacement, self-priming plunger
- Mounted on fabricated steel base
- Powered by electric motor through a gear reducer
- Fluid contacting components - 300 series stainless steel

**Applications:**

- Plant Operations
- Research
- Oilfield Applications
- Refineries
- Water Treatment for boilers
- Injection of precise small volumes

\* 1/2 & 3/4 HP MOTORS ARE AVAILABLE  
 APPROX. WEIGHT: 130 LBS.



# McFarland – TriTan, LLC

The "High Pressure" Specialists!  
 www.mcfarlandpumpgroup.com  
 Phone: (713) 864-3366 FAX: (713) 864-3252

# STONEBOR MODEL B SIMPLEX CHEMICAL INJECTION PUMP

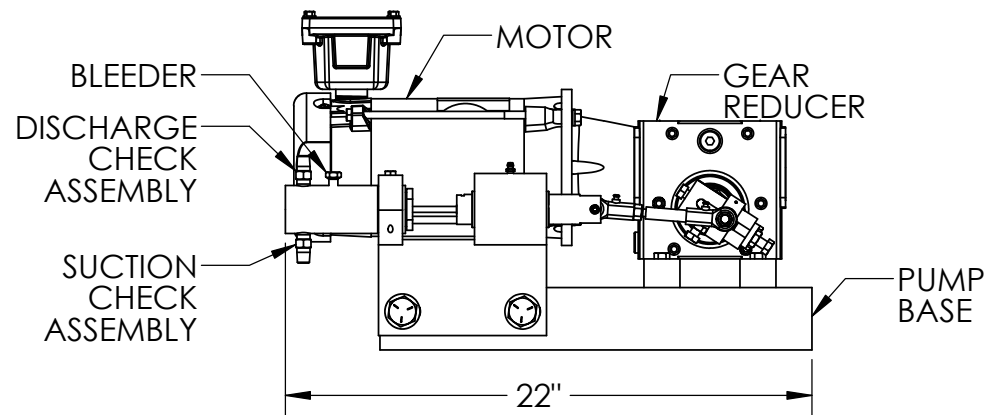
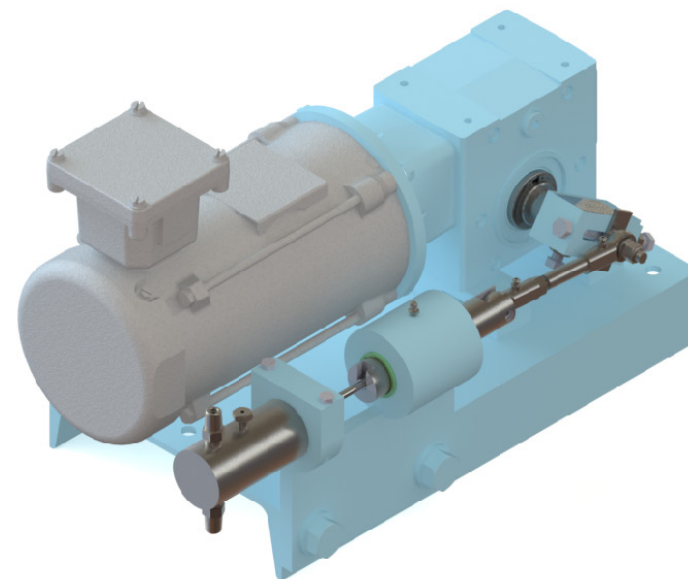
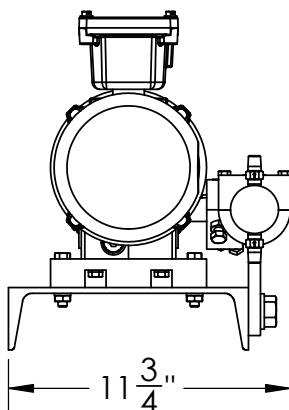
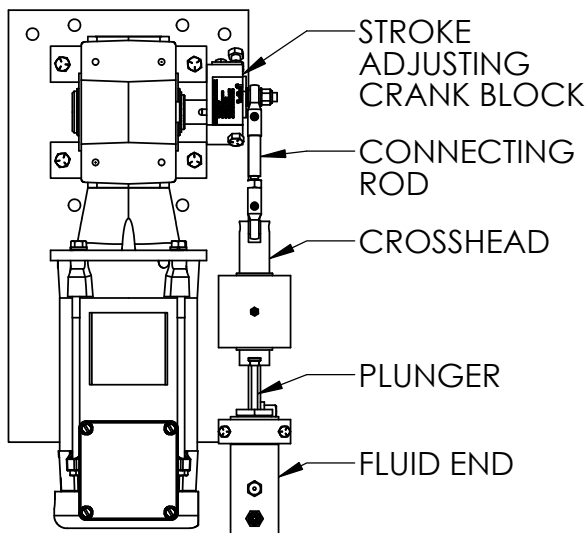

| MODEL      | Volume Gal./Day | Plunger Size (in.) | Max Discharge Pressure (PSI) | Stroke (Max) | Speed Strokes/Minute |
|------------|-----------------|--------------------|------------------------------|--------------|----------------------|
| B-S-250-A  | 36.15           | 1/4                | 4,000                        | 1.5"         | 87.5                 |
| B-S-375-A  | 81.33           | 3/8                | 3,000                        | 1.5"         | 87.5                 |
| B-S-500-A  | 144.58          | 1/2                | 1,750                        | 1.5"         | 87.5                 |
| B-S-750-A  | 325.32          | 3/4                | 800                          | 1.5"         | 87.5                 |
| B-S-1000-A | 578.34          | 1                  | 500                          | 1.5"         | 87.5                 |

\* 1/2 & 3/4 HP MOTORS ARE AVAILABLE  
 APPROX. WEIGHT: 110 LBS.

Model A & Model B electric pumps are designed for continuous and intermittent pumping of chemical and corrosive fluids.

#### Features:

- Positive displacement, self-priming plunger
- Mounted on fabricated steel base
- Powered by electric motor through a gear reducer
- Fluid contacting components - 300 series stainless steel

#### Applications:

- Plant Operations
- Research
- Oilfield Applications
- Refineries
- Water Treatment for boilers
- Injection of precise small volumes



# McFarland - TriTan, LLC

The "High Pressure" Specialists!  
 www.mcfarlandpumpgroup.com  
 Phone: (713) 864-3366 FAX: (713) 864-3252

# STONEBOR MODEL B QUADRUPLEX CHEMICAL INJECTION PUMP

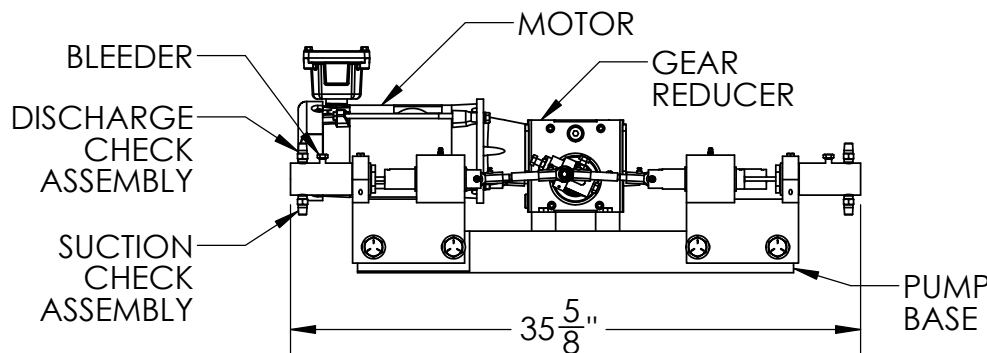
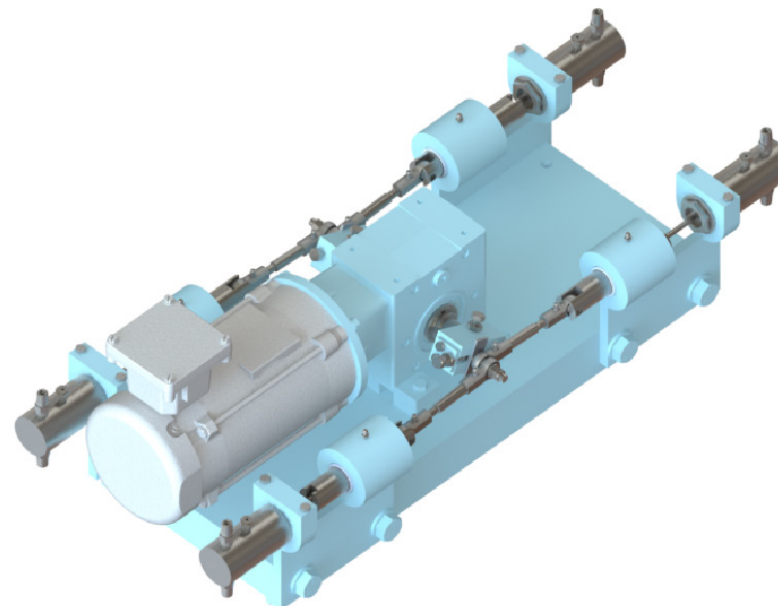
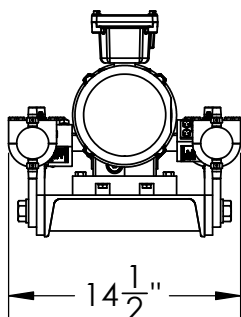
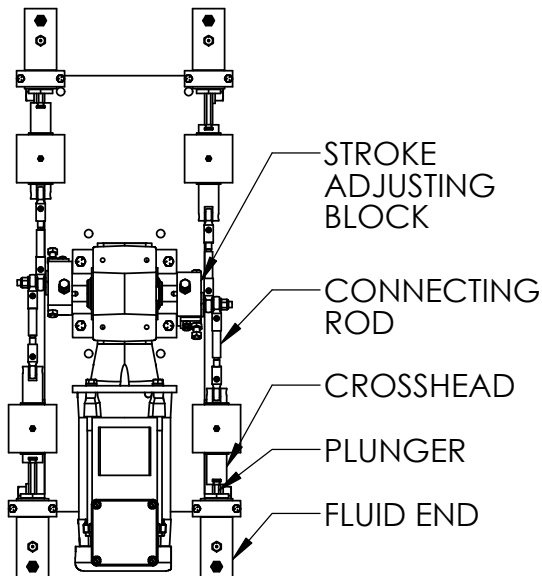

| MODEL      | Volume Gal./Day | Plunger Size (in.) | Max Discharge Pressure (PSI) | Stroke (Max) | Speed Strokes/Minute |
|------------|-----------------|--------------------|------------------------------|--------------|----------------------|
| B-Q-250-A  | 144.60          | 1/4                | 4,000                        | 1.5"         | 87.5                 |
| B-Q-375-A  | 325.32          | 3/8                | 3,000                        | 1.5"         | 87.5                 |
| B-Q-500-A  | 578.32          | 1/2                | 1,750                        | 1.5"         | 87.5                 |
| B-Q-750-A  | 1,301.30        | 3/4                | 800                          | 1.5"         | 87.5                 |
| B-Q-1000-A | 2,313.40        | 1                  | 500                          | 1.5"         | 87.5                 |

Model A & Model B electric pumps are designed for continuous and intermittent pumping of chemical and corrosive fluids.

**Features:**

- Positive displacement, self-priming plunger
- Mounted on fabricated steel base
- Powered by electric motor through a gear reducer
- Fluid contacting components - 300 series stainless steel

**Applications:**

- Plant Operations
- Research
- Oilfield Applications
- Refineries
- Water Treatment for boilers
- Injection of precise small volumes

\* 1/2 & 3/4 HP MOTORS ARE AVAILABLE  
 APPROX. WEIGHT: 200 LBS.



# McFarland - TriTan, LLC

The "High Pressure" Specialists!  
 www.mcfarlandpumpgroup.com  
 Phone: (713) 864-3366 FAX: (713) 864-3252

# STONEBOR MODEL B SIMPLEX CHEMICAL INJECTION PUMP

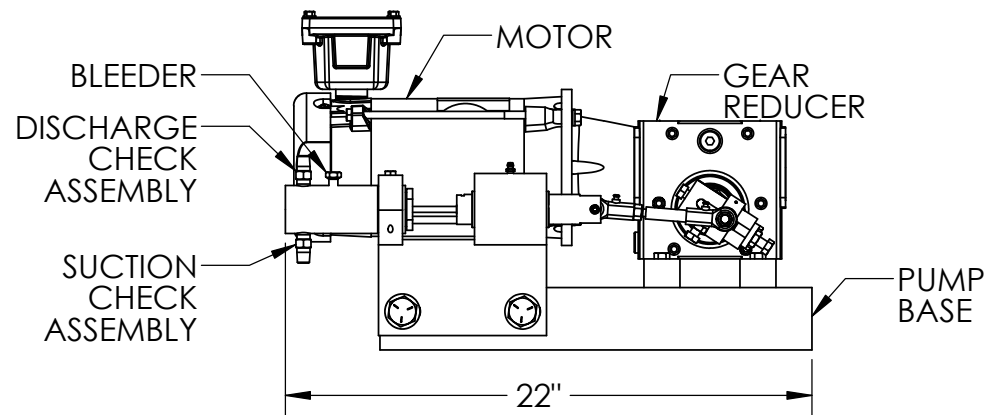
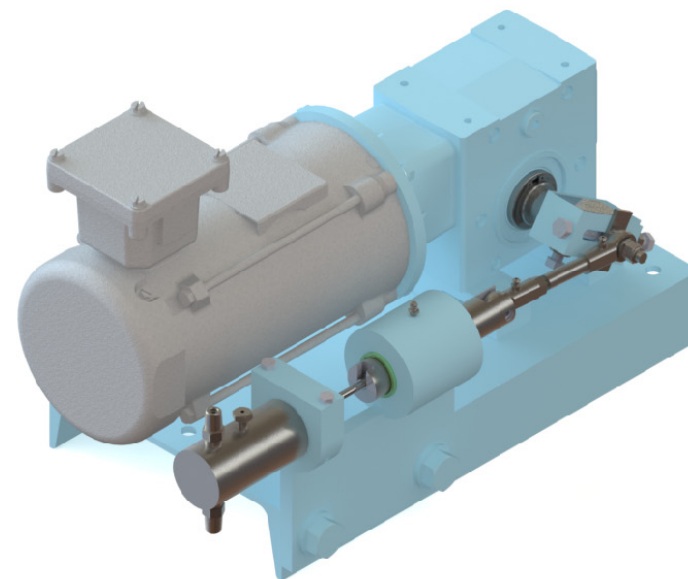
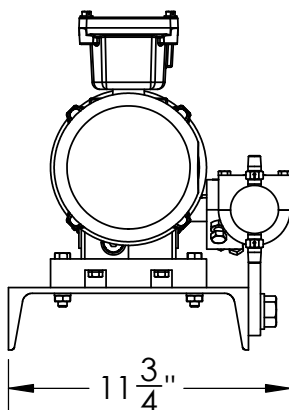
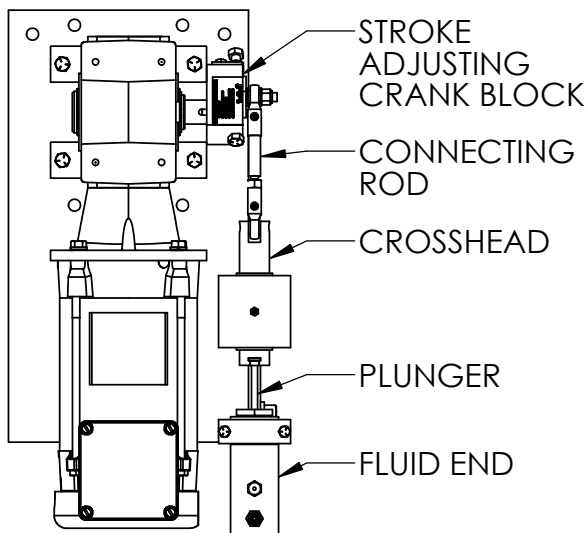

| MODEL      | Volume Gal./Day | Plunger Size (in.) | Max Discharge Pressure (PSI) | Stroke (Max) | Speed Strokes/Minute |
|------------|-----------------|--------------------|------------------------------|--------------|----------------------|
| B-S-250-A  | 36.15           | 1/4                | 4,000                        | 1.5"         | 87.5                 |
| B-S-375-A  | 81.33           | 3/8                | 3,000                        | 1.5"         | 87.5                 |
| B-S-500-A  | 144.58          | 1/2                | 1,750                        | 1.5"         | 87.5                 |
| B-S-750-A  | 325.32          | 3/4                | 800                          | 1.5"         | 87.5                 |
| B-S-1000-A | 578.34          | 1                  | 500                          | 1.5"         | 87.5                 |

\* 1/2 & 3/4 HP MOTORS ARE AVAILABLE  
 APPROX. WEIGHT: 110 LBS.

Model A & Model B electric pumps are designed for continuous and intermittent pumping of chemical and corrosive fluids.

### Features:

- Positive displacement, self-priming plunger
- Mounted on fabricated steel base
- Powered by electric motor through a gear reducer
- Fluid contacting components - 300 series stainless steel

### Applications:

- Plant Operations
- Research
- Oilfield Applications
- Refineries
- Water Treatment for boilers
- Injection of precise small volumes